



Drilling and milling head, angular, left hand, short collet chuck, ER40, external and central coolant supply

Part Number 7.077.882
for BMT BMT75 *

Ratio 2:1
rpm at Input max. 3000 rpm
rpm at Output max. 1500 rpm
Torque at Output max. 100 Nm
Direction of Rotation 
Scope of Delivery without wrench and collets

Accessories Collets see Equipment for Toolholders Z2.1
 Wrench for spindle 0.002.277
 PRECI-FLEX® Adapter
 Coolant tubes 0.000.378
 Collet nut 15812

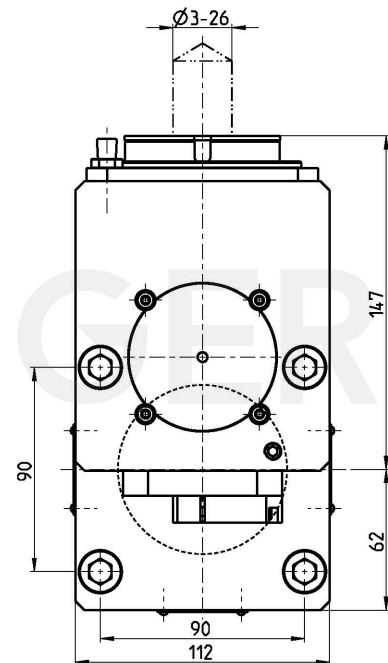
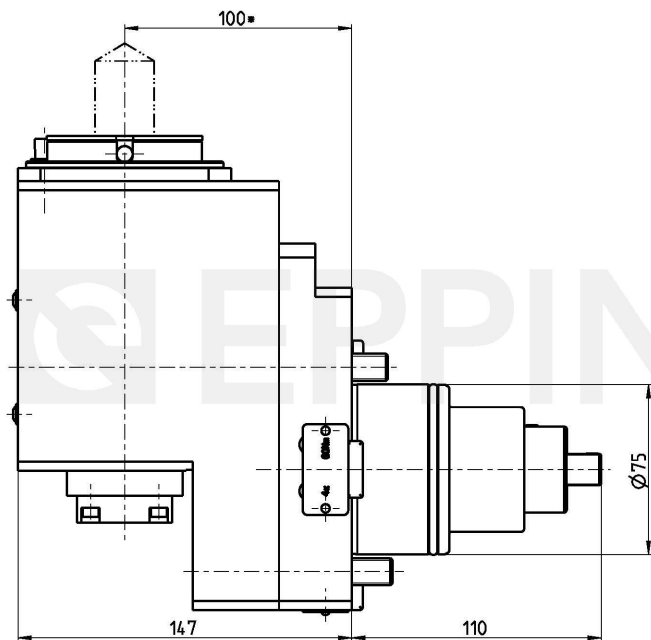

Technical Data Subject to Change

18.11.2013 | 18.11.2013